

# CORNER RECORD

Agency Index CR-23-243  
Document Number \_\_\_\_\_

City of UNINCORPORATED AREA County of SAN JOAQUIN, California

Brief Legal Description 3/4" IRON PIPE PER BOOK 13 OF PARCEL MAPS AT PAGE 65

### CORNER TYPE

### COORDINATES (Optional)

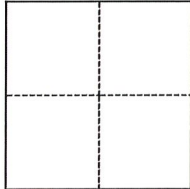

- Government Corner
- Meander
- Rancho
- Control
- Property
- Other

Date of Survey 09/25/2023

N. \_\_\_\_\_ E. \_\_\_\_\_

Elevation \_\_\_\_\_

Units  Metric  U.S. Survey Foot

Horizontal Datum \_\_\_\_\_

Zone \_\_\_\_\_ Epoch Date \_\_\_\_\_

Vertical Datum \_\_\_\_\_

Complies with Public Resources Code §§8801-8819

Complies with Public Resources Code §§8890-8902

PLS Act Ref.:  8765(d)  8771  8773  Other:

Corner/Monument:  Left as found  Established  Rebuilt  Pre-Construction

Found and tagged  Reestablished  Referenced  Post-Construction

Narrative of corner identified and monument as found, set, reset, replaced, or removed:

See sheet #2 for description(s):

*FOUND 3/4" IRON PIPE AT THE NORTHWEST CORNER OF PARCEL "A" PER PRE-CONSTRUCTION CORNER RECORD CR-23-130 AND BOOK 13 OF PARCEL MAP AT PAGE 65. FOUND FOUR (4) REFERENCE POINTS, AS SHOWN ON SIDE 2, OUTSIDE OF CONSTRUCTION LIMITS.*

### SURVEYOR'S STATEMENT

This Corner Record was prepared by me or under my direction in conformance with

the Professional Land Surveyors' Act on SEPTEMBER 26, 2023

Signed *James N. Landrum* P.L.S. or R.C.E. No. LS 5837



### COUNTY SURVEYOR'S STATEMENT

This Corner Record was received October 9, 2023

and examined and filed October 30, 2023

Signed *James E. Hart* P.L.S. or R.C.E. No. 8657

Title County Surveyor

County Surveyor's Comment



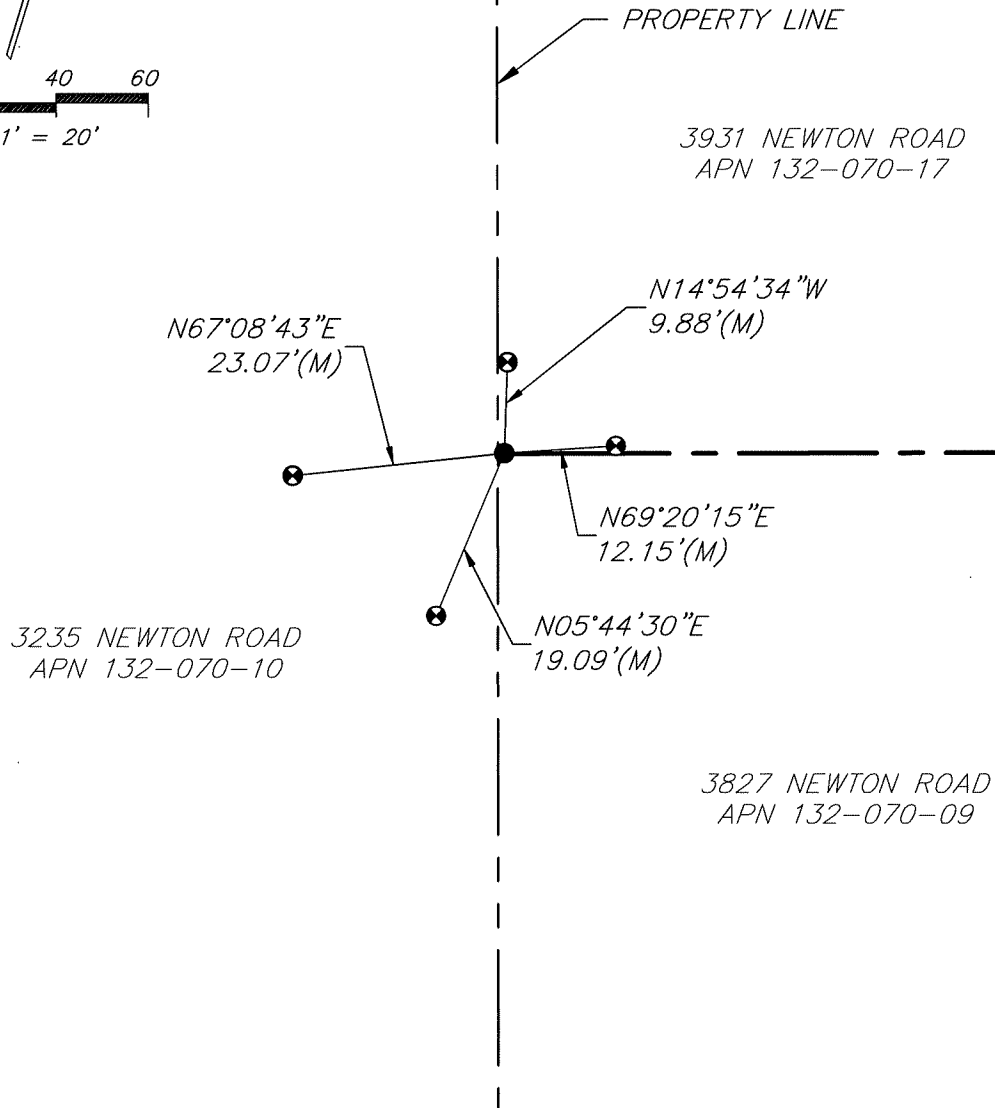
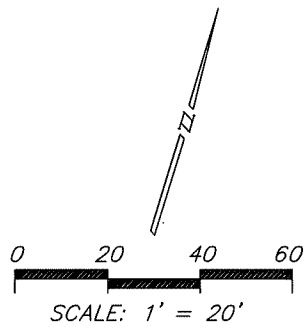

**LEGEND**

- FOUND 3/4" IRON PIPE
- ⊙ FOUND HUB AND TACK UNLESS OTHERWISE SHOWN
- (M) MEASURED ON THIS SURVEY
- (A) BOOK 13 OF PARCEL MAPS, PAGE 65

**NOTES**

1. NOTE THAT BEARINGS SHOWN ARE FOR ANGULAR CONTROL FROM LOCAL CONSTRUCTION SURVEY DATA.