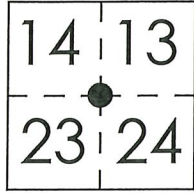

CORNER RECORD

Agency Index CR-20-16

Document Number _____

City of _____ County of San Joaquin, CaliforniaBrief Legal Description Peltier Road 3570± east of Thornton RoadT4N R5E
MDB&M**CORNER TYPE**
 Government Corner Control
 Meander Property
 Rancho Other
Date of Survey October 17, 2019**COORDINATES (Optional)**

N. _____ E. _____

Elevation. _____

Units Metric U.S. Survey Foot

Horizontal Datum _____

Zone _____ Epoch Date _____

Vertical Datum _____

 Complies with Public Resources Code §§8801-8819 Complies with Public Resources Code §§8890-8902PLS Act Ref.: 8765(d) 8771 8773 Other:Corner/Monument: Left as found Established Rebuilt Pre-Construction Found and tagged Reestablished Referenced Post-Construction

Narrative of corner identified and monument as found, set, reset, replaced, or removed:

 See sheet #2 for description(s):**SURVEYOR'S STATEMENT**This Corner Record was prepared by me or under my direction in conformance with the Professional Land Surveyor's Act on December 06, 2019.Signed James E. Hart P.L.S. or R.C.E. No. 8657**COUNTY SURVEYOR'S STATEMENT**This Corner Record was received December 17, 2019and examined and filed January 10, 2020.Signed James E. Hart P.L.S. or R.C.E. No. 8657

Title _____ County Surveyor

County Surveyor's Comment

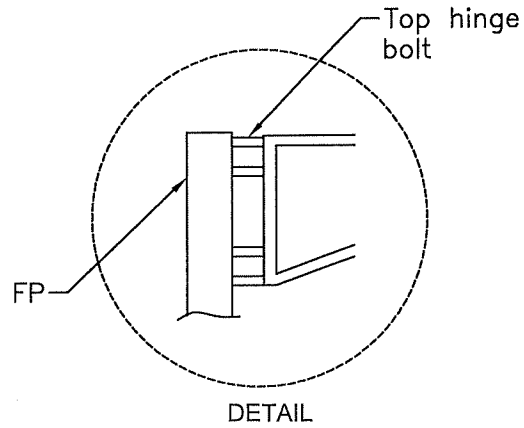
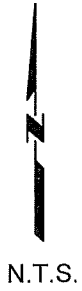

DETAIL

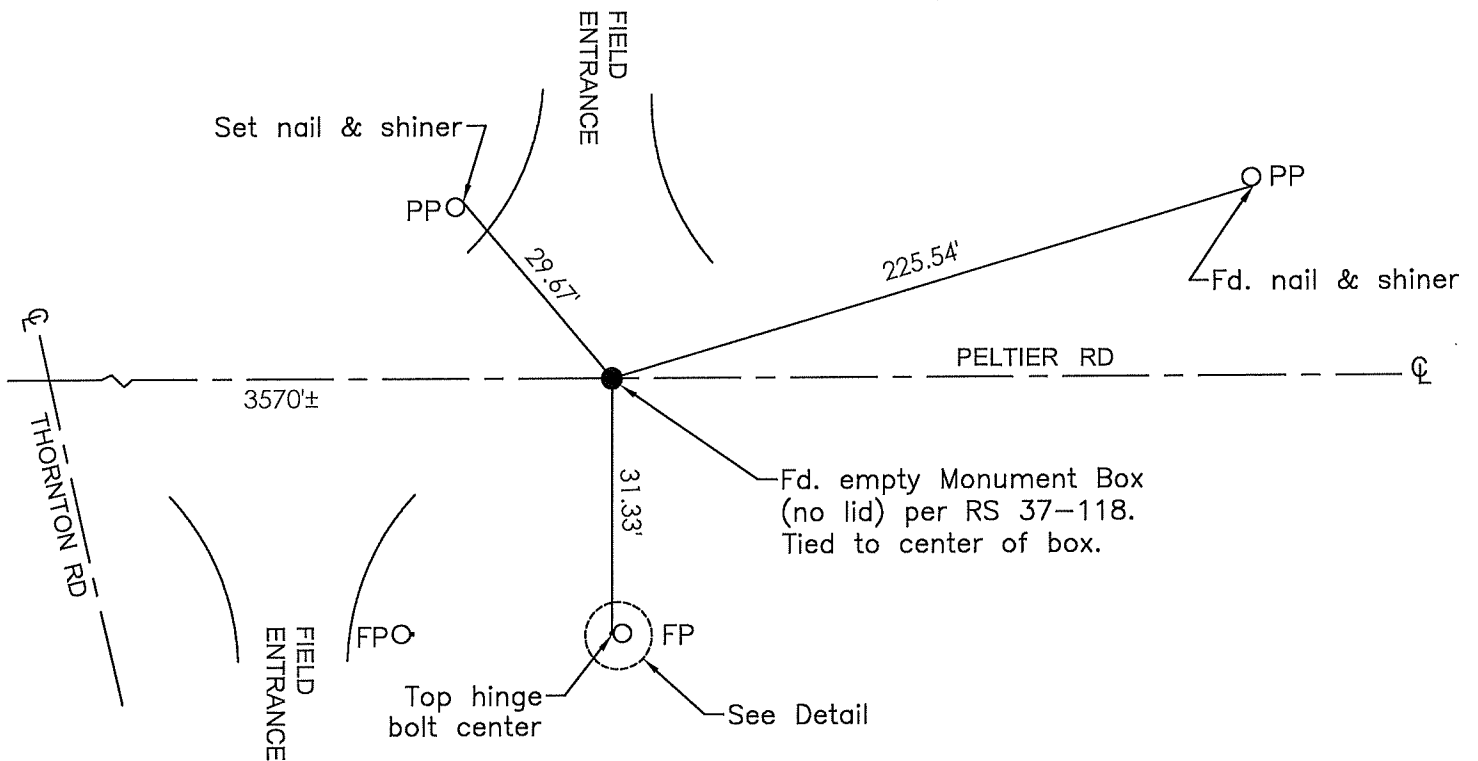

- CR=Corner Record
- FP=Fence Post
- JP=Joint Pole
- LP=Light Pole
- PP=Power Pole
- GP=Guy Pole
- SP=Service Pole
- TP=Telephone Pole
- S.F.N.=Searched Found Nothing
- N.T.S.=Not To Scale
- M&P=Maps & Plats
- FB=Field Book
- PM=Parcel Map
- RS=Record of Survey
- N=North
- DI=Drain Inlet
- TOC=Top of Curb

Set=Conc. Nail with Brass Washer stamped
 "S.J. Co.", unless otherwise noted
 Fd.=Found Conc. Nail with Brass Washer stamped
 "S.J. Co.", unless otherwise noted
 Note: Found Monuments are not tagged
 unless otherwise noted.

"No attempt was made to verify the Monument(s)"